

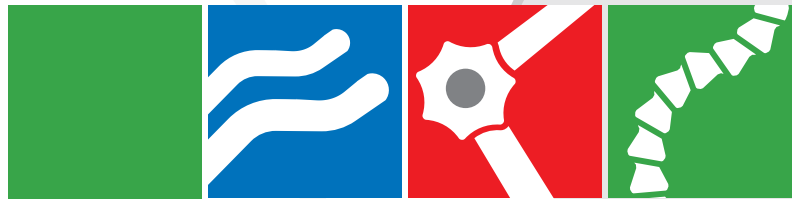

simply sophisticated



NEW Products 2016



NEW PRODUCTS

High Pressure

**Fixed & Vari
Cool Arms**

Fixed & Vari HP Cool Arms

Noga is introducing its patent pending newest product to the Cooling Systems line. Our **High Pressure** (HP) Arms will become synonymus in the industry for stability and flexibility.

The Fixed HP Cool Arm and Vari HP Cool Arm can be fitted with three different sizes of nozzles which will deliver fluids or cooling liquids at high pressure, up to 1000 PSI, allowing a higher level of machining. The arms are easy and fast to set in position.

**PATENT
PENDING**

CA2000 Fixed HP Cool Arm

Single arm with 2 end ball joints so the nozzles can move on wide curve for positioning.



Dimensions:
Length: 164 mm
Thread: Int. NPT 1/4"

CA3000 Vari HP Cool Arm

Long Articulated Arms provide full axis rotation. Sturdy tightening fixtures for total stability.



Dimensions:
Length: 238 mm
Thread: Int. NPT 1/4"

Both CA2000 and CA3000 are provided with:
CA1010 Hex Key
CA1004 Nozzle 4 mm standard

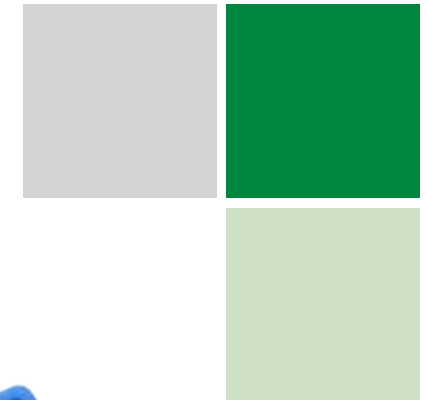

CA1010 Hex Key 5 mm



CA1002 Nozzle 2 mm



CA1004 Nozzle 4 mm - standard



CA1006 Nozzle 6 mm

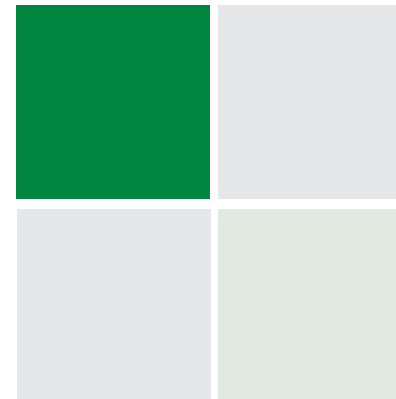

NEW PRODUCTS



**Fine
Mini Set**

Fine Mini Set

FT10001 Mini Extra Fine Deburring Tool

Deburring tool with the finest HSS blade S150 for extra fine jobs



FT11001 Mini Scraper

Fine triangular HSS mini-scraper D50 ideal for tool and die maker



FT12001 Mini Rotodrive Countersink

3.2 mm Rotodrive countersink blade deburrs and countersinks small holes 0 - 3 mm Dia.

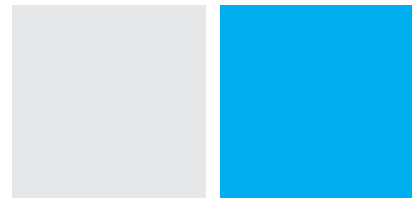

FT3000 Fine Mini Set

Set Includes:
FT10001
FT11001
FT12001



Blades are not replaceable.



NEW PRODUCTS



Non Scratch

NG1910 Tool with non scratch blade with safety cap

Removing burrs from workpieces may sometimes leave unsightly scratches, Noga's NG-1 handle with the NEW non scratch blade with safety cap will prevent friction therefore eliminating scratches. Works best on steel, aluminum and plastic materials.



Includes:

NG1000 NG-1 Handle

Ergonomically and hand perfect fit handle



BS9110 Non Scratch HSS Blade with safety cap

Plastic safety cap will protect workpiece surface from scratches



NEW PRODUCTS



Ceramic Tools

CR1500 Mini Ceramic Handle and Convex Blade

Ideal for surface scraping and parting line deflashing. Perfect for all plastic materials and soft metals. Replacement blades available.



Includes:

CR1400 Mini Ceramic Handle

A unique mini plastic handle that holds the blade by its self gripping taper. Storage space for blades.



CR1550 Mini Convex Blade

Ideal for surface scraping and parting line deflashing on small fine parts.



Ceramic Tools

CR4100 Adjustable Ceramic Mini Scraper

Ceramic mini scraper ideal for surface cleaning, trimming deburring and parting line deflashing almost all plastics. Special blade design for safety.



Includes:

YT10004 Ceramic Mini Scraper Handle

The perfect grip for adjustable ceramic mini scrapers

Range:
2.2 - 4.5 mm



CR4500 Ceramic Blade

Fine ceramic mini-scraper blade



Dimensions:
4 x 50 mm

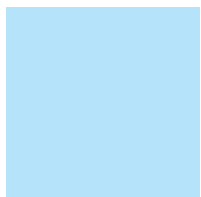

NEW PRODUCTS



MultiBurr
RG1000

The handy universal deburring set with multi-purpose blades will help you produce a perfect finish for a wide variety of jobs.

This innovative tool set has 4 folding shafts which can be easily locked into position for the duration of the work and then folded neatly back into the handle allowing the tool to be carried simply anywhere.

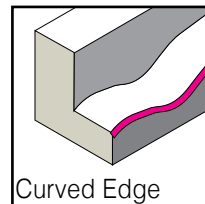
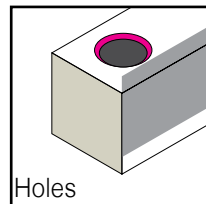
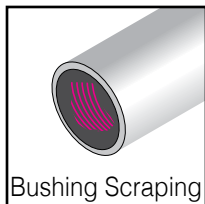
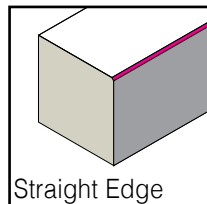

*Only single blade included in tool set

NEW PRODUCTS

45mm Clamp

CS4550 CLAMP

The strong CS4550 clamp with its special soft grip expands onto round and flat surfaces up to 45 mm.

Features internal threads: 2 x 1/4", 2 x 3/8", 1 x 6 mm, 1 x 8 mm.



Quick Release

AD4000

Bottom Thread Ext. M6

Top Thread Ext. 1/4" UNC



Make a quick change to your equipment without having to fiddle with screws and threads.

In low light, tight space or with no time to lose, whatever the conditions simply pull back the red sleeve and slot in your camera, light source or any other device into the Quick Release attachment.

Quick Release can be held by a range of Noga arms.



NEW PRODUCTS
FAT & FAB



NF 6160
NF Holder with
Double Fine Adjustment

- New double fine adjustment:
 BOTTOM: unique single direction
 TOP: universal swivel clamp
- Holds 6 mm, 8 mm, 3/8", dovetail and back lug.
- Unique central locking mechanism with Noga designed spring loaded bearing.
- Five axis holder.
- Powerful ON/OFF magnetic base 32 kg (70 lbs)
- Instantly fastens in any position
- Fast and easy to set up gauges into required position
- Black finished arms

Dimensions:
 Bottom Arm: 56 mm
 Top Arm: 51 mm

NF 6160

- Includes:
- NF60003 NF Arms
 - FA1500 Zinc cast fine adjustment
 - NF3778 ON/OFF magnetic base with fine adjustment

Indicator is not included

NEW PRODUCTS

MG 6161
MG Holder with Double Fine Adjustment

- New double fine adjustment:
BOTTOM: unique single direction
TOP: universal swival clamp
- Holds 6 mm, 8 mm, 3/8", dovetail and back lug.
- Unique central locking mechanism with Noga designed spring loaded bearing.
- Five axis holder.
- Powerful ON/OFF magnetic base 80kg (176 lbs)
- Instantly fastens in any position
- Fast and easy to set up gauges into required position
- Black finished arms



FAT & FAB

Dimensions:
Bottom Arm: 133 mm
Top Arm: 113 mm

MG 6161

- Includes:
- MG60003 MG Arms
 - FA1500 Zinc cast fine adjustment
 - DG3678 ON/OFF magnetic base with fine adjustment

Modular System

Professional Variable Arm System

This new addition to Noga's modular holders allows you to assemble a specific holding system from delicate fine positioning to heavy duty support.

The Noga Variable Arm features a double-articulated, triple-jointed arm that can be locked into limitless angles which enables you to support circuit boards, lights, monitors or secure any compact table-top subject. Noga Holding Systems gives you the versatility and dependability no regular bracket, clip, clamp, wire or balancing act can.

When it's vital you're not let down by inflexible and time-wasting equipment the Noga Holding System keeps you in control.

Ingenious technology at the heart of your art



Modular Holders

Modular Holders

Three different sizes of articulated arms are offered for a wide range of applications.

Choose the arms that fit your needs.

A number of accessories are shown on next page

Order No.	Weight	Int. Thread		Arms Length		
		D1	D2	L1	L2	Total L1+L2
NF60003	0.210	M6	M6	56	51	107
DG60003	0.250	M6	M6	110	101	211
MG60003	0.750	M8	M6	133	113	246

ACCESSORIES

M6

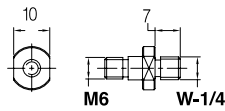
AD6010  

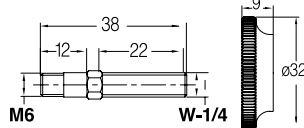
AD6015  

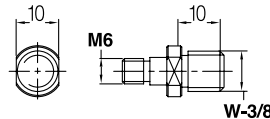
AD6030  

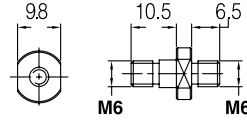
AD6060  

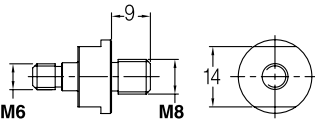
AD6080  

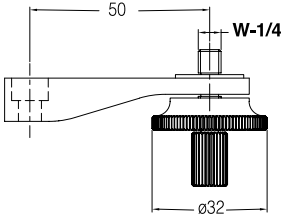
MA0125  

M8 & M10 x 1.25

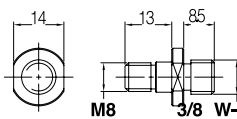
AD8030  

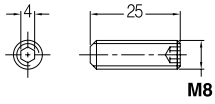
AD8080  

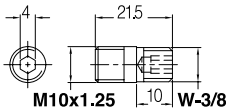
AD1030  

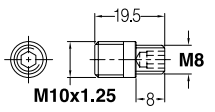
AD1080  

CLAMPS

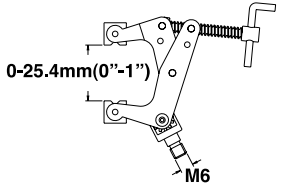
NF0125  

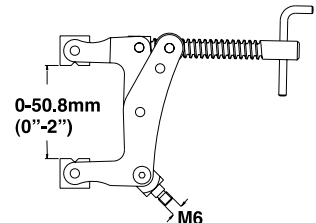
DG0125  

DG Magnets

Vacuum Base

MG & MA Clamps

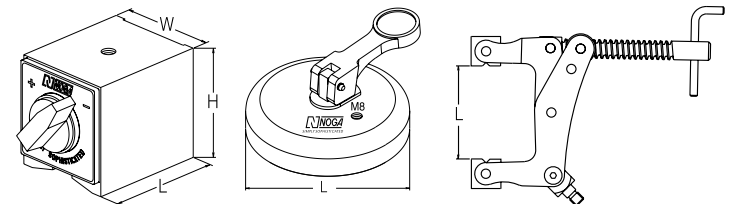

Order No.	Max. Load Type	Weight		Force [N]	Thread	L		W		H	
		Kg	lbs			mm	inch	mm	inch	mm	inch
DG0036	ON/OFF Magnet	1.000	2.200	800	M8	60	2.36	50	1.97	55	2.16
DG1003	ON/OFF Magnet multi thread	1.350	2.380	1000	M6/8/10/12 10x 1.25	75	2.95	50	1.97	55	2.16
DG0040	Vacuum Base	0.400	0.880	350	M8	∅ 100	-	-	-	-	-
MG0125	3" Clamp with plastic cover	0.600	1.320	-	Int. M8	75	2.95	-	-	-	-
MG1006	3" Clamp	0.570	1.254	-	Ext. M8	75	2.95	-	-	-	-
MG1003	3" Clamp	0.600	1.320	-	Int. M8	75	2.95	-	-	-	-
MA0320	4" Clamp	1.160	2.552	-	Int. M10 x 1.25	100	3.94	-	-	-	-



NEW
PRODUCTS
2016



Noga Engineering and Technology (2008) Ltd.
P.O.B. 55. Dora Industrial Park
Shlomi 22832, Israel
Tel: 972-4-9808080
Fax: 972-4-9808638
E-mail: noga@noga.com
www.noga.com